

Introducing IS31LT3117 – High current linear LED driver

Light Emitting Diodes (LEDs) are devices which require a driver with a high enough voltage to turn on (illuminate) the LED at a constant current. The voltage required to illuminate the LED is called the forward voltage (V_f). The amount of current the LED uses when illuminated is called the forward current (I_f). Light output will vary with the forward current; decreasing the forward current decreases the light output. Operating the LED above its rated maximum current will damage it; operating the LED within its current range will guarantee improved efficacy, reliability, and long operating life.

Basically there are only two LED driver types to select from; either linear or switching. Some of the key parameters to consider when selecting the proper LED driver are: EMI noise acceptability, supply voltage to total LED forward voltage, design/BOM complexity, driver efficiency, etc. Switching drivers are efficient but complex since they require an MOSFET, inductor, and diode combination which will generate EMI noise.

Linear drivers are your no nonsense basic current controllers requiring minimum components and don't generate EMI. Perhaps the only problem is they tend to get hot which limits their operation to tens of milliamps. Fortunately, ISSI has a variety of linear drivers with built in thermal management capability to cover a wide current range; from milliamps to amps.

The recently introduced IS31LT3117 is an industry unique, four channel linear driver for high brightness LEDs. With an operating voltage range of 6V to 53V it can sink up to 350mA per channel. If a higher current is required, the four outputs can be connected in parallel for a whopping 1.4 amps (4 x 350mA) of combined current!

Operating at such high currents presents thermal challenges which are addressed in the IS31LT3117. First it is packaged in a thermally enhanced 16pin TSSOP to mechanically disperse heat to the PCB. Then it integrates thermal protection features and supports external transistors to offload any excess heat away from the device and unto the transistors.

The IS31LT3117's silicon junction temperature is constantly monitored to keep it below 160°C and will shut down should this threshold be exceeded. However, to avoid a complete shutdown, the output current is reduced at a rate of 2.22%/°C when the junction temperature increases beyond 130°C (Fig 1). Should the die temperature continue to rise and exceed 160°C then the device will automatically shut down with no current to the LEDs. As the device cools and the junction temperature drops to below 140°C, the device will once again operate and restore current to the LEDs.

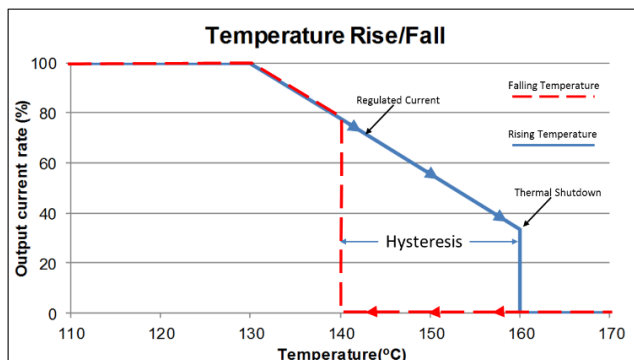

Fig1. IS31LT3117 Thermal Protection

However, there are applications where this thermal hysteretic ON/OFF cycling can be a nuisance. To avoid this the IS31LT3117 provides a 2.5V reference voltage (VREF) used for driving external transistors (BJTs) and offload the heat away from the device (Fig 2). The amount of heat generated is related to the power loss: $P = V * I$; therefore increasing either voltage (V) or current (I) will increase the generated heat (power loss). The external transistors are employed to take on any excess voltage; ie excess power, $P_{BJT} = (V_{supply} - V_f) * I_f$.

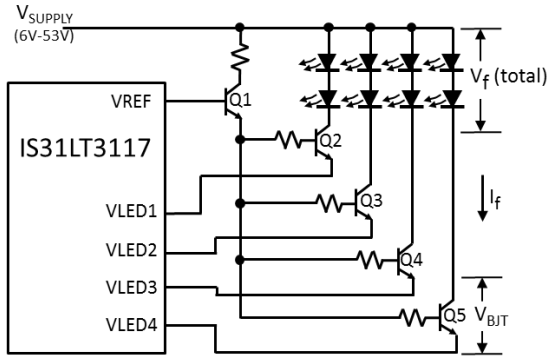

Fig 2 External Transistor Configuration

Linear drivers are a simple and cost effective solution for driving LEDs; if their heat generation is properly managed. The IS31LT3117 is the right LED driver solution for high brightness LED lighting applications since it provides all the benefits of a linear driver while addressing the thermal issues. ISSI offers two evaluation boards for the IS31LT3117, a non-BJT and a BJT version. The “non-BJT” (Fig 3) is recommended for high current applications where the total LED string forward voltage (V_f) is within 1 volt of the supply voltage; $V_{SUPPLY} - V_f(\text{total}) < 1V$. The “BJT” version (Fig 4) is recommended for high current applications where $V_{SUPPLY} - V_f(\text{total}) > 1V$.



Fig 3 Non-BJT IS31LT3117 Eval Board



Fig 4 BJT IS31LT3117 Eval Board